

# AT-H serie

## Overzicht

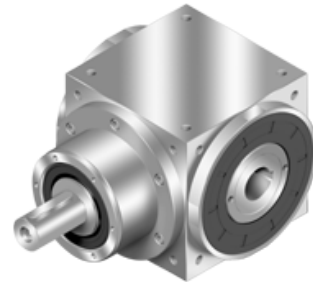

- Spiraal kegelwiel reductor met één ingaande as en een uitgaande haakse doorlopende holle as
- Roestvast stalen behuizing
- Roestvast stalen uitgaande holle as met spiebaan
- Nominale koppels:
  - $T_{2N}$  : 12 Nm – 3.200 Nm
- Overbrengverhouding
  - 1-stage : 1 / 1,5 / 2 / 3 / 4 / 5
- Spelingarm
  - 1-traps :  $\leq 6$  arcmin
- Hoog rendement
  - 1-traps :  $\geq 98\%$
- Eenvoudige montage
- Compacte bouw
- Bouwgrootte: AT065H / AT075H / AT090H / AT110H / AT140H / AT170H / AT210H / AT240H / AT280H

# Specificaties

Bouwgrootte		Trap	Ratio <sup>1</sup>	AT065	HAT075	HAT090	HAT110	HAT140	HAT170	HAT210	HAT240	HAT280H
Nominaal uitgangskoppel T <sub>2N</sub>	Nm	1	1	25	45	78	150	360	585	1,300	2,150	3,200
			1.5	25	45	78	150	360	585	1,300	2,150	3,200
			2	24	42	68	150	330	544	1,220	2,010	3,050
			3	18	33	54	120	270	450	1,020	1,650	2,850
			4	13	28	48	100	224	376	860	1,410	2,300
			5	12	25	40	85	196	320	740	1,210	2,000
Max Versnellingskoppel T <sub>2B</sub>	Nm	1	1~5	1.5 keer Nominaal koppel T <sub>2N</sub>								
Max. Versnelling Ingangssnelheid n <sub>1B</sub>	rpm	1	1~5	7,500	6,500	5,500	4,500	3,500	3,000	2,200	2,000	1,700
Verdraaispeling*	arcmin	1	1~5	≤ 6	≤ 6	≤ 6	≤ 6	≤ 6	≤ 6	≤ 6	≤ 6	≤ 6
Max. Radiale Last F <sub>1rB</sub> 2 Ingang d1	N	1	1~5	700	950	1,450	2,100	2,700	3,800	7,800	9,600	10,500
Max. Radiale Last F <sub>2rB</sub> 3 Uitgang d2	N	1	1~5	900	1,100	1,700	2,700	4,800	6,600	11,500	16,000	18,000
Max. Axiale Last F <sub>1aB</sub> 2 Ingang d1	N	1	1~5	350	425	725	1,050	1,350	1,900	3,900	4,800	5,250
Max. Axiale Last F <sub>2aB</sub> 3 Uitgang d2	N	1	1~5	450	550	850	1,350	2,400	3,300	5,750	8,500	9,000
Service Life	hr	1	1~5	20,000*								
Rendement	%	1	1~5	≥ 98 %								
Gewicht	kg	1	1~5	2.5	3.9	6.4	11.0	18.1	31.6	60.0	89.4	143.4
Bedrijfstemperatuur	°C	1	1~5	-10°C~+90°C								
Smeermiddel		1	1~5	synthetisch smeermiddel, ISO VG 150								
Geluidsniveau (n <sub>1</sub> =1500 rpm, No Load)	dB(A)	1	1~5	≤68	≤70	≤74	≤76	≤77	≤78	≤80	≤82	≤83

1. Overbrengverhouding (ratio) (  $i=N_{in} / N_{out}$  )
2. Uitge oefend op het midden van de ingaande as @ 100 rpm
3. Uitge oefend op het midden van de uitgaande as @ 100 rpm

\* S1 service life 10,000 uren

\* Verdraaispeling is gemeten met 2% van het Nominaal koppel T<sub>2N</sub>

## Draairichting

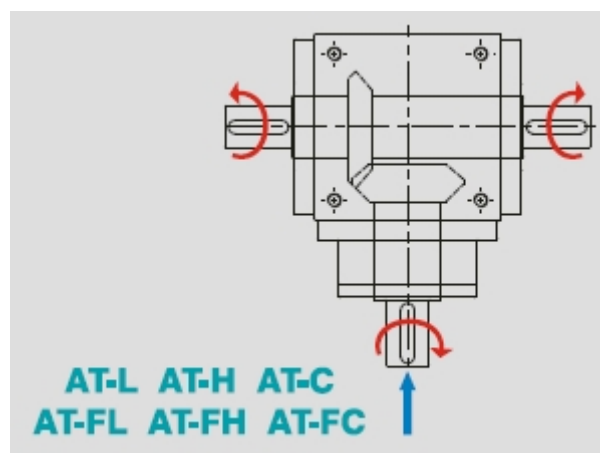

# Massatraagheid

Bouwgrootte	Trap	Ratio <sup>1</sup>	AT065H	AT075H	AT090H	AT110H	AT140H	AT170H	AT210H	AT240H	AT280H
Massatraagheid of inertia $J_1$	1	1	0.51	1.30	3.16	7.70	23.57	58.99	195.40	369.34	799.12
		1.5	0.64	1.16	2.82	6.74	19.37	49.28	155.45	283.58	595.78
		2	0.44	1.11	2.70	6.31	17.75	45.35	140.24	249.74	511.76
		3	0.43	1.09	2.66	6.17	17.18	44.01	134.95	237.71	483.06
		4	0.43	1.09	2.65	6.13	17.06	43.70	133.58	234.72	476.26
		5	0.43	1.09	2.65	6.12	17.02	43.60	133.14	233.67	473.58

# Afmetingen

## AT-H serie 1-traps

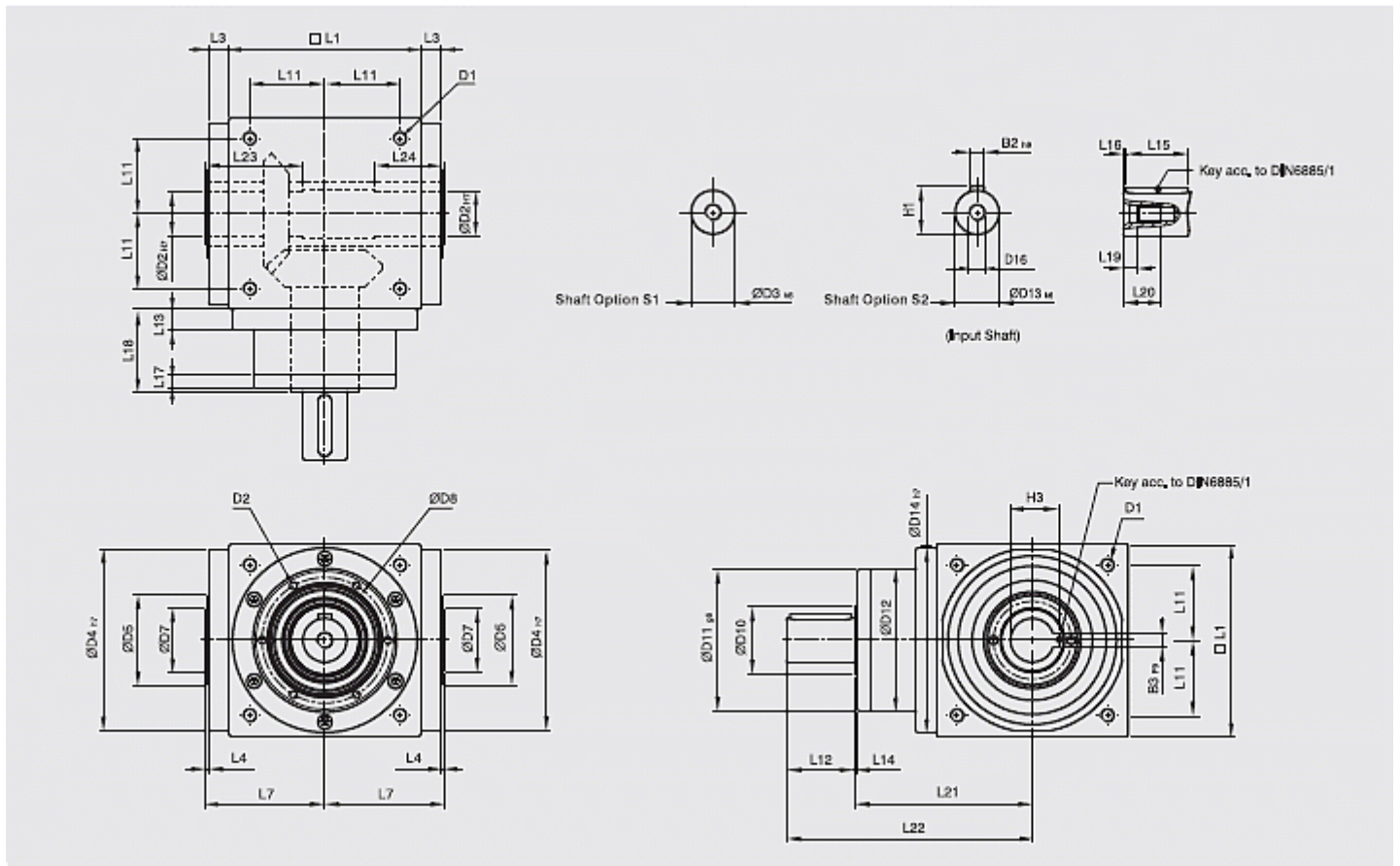

	AT065H	AT075H	AT090H	AT110H	AT140H	AT170H	AT210H	AT240H	AT280H
D1	M4	M6	M6	M8	M10	M12	M16	M16	M16
D2 <sub>H7</sub>	13	14	18	22	32	40	50	55	60
D4 <sub>H7</sub>	63	73	88	108	135	165	205	235	275
D5	31	35	43	53	68	83	104	124	144
D7	21	22	28	33	47	55	75	85	110
D8	53	62	76	95	92	114	142	160	176
D9	4xM4xL7	4xM5xL8	4xM5xL8	6xM6xL10	6xM6xL10	6xM8xL12.5	6xM8xL12.5	6xM8xL12.5	6xM10xL15
D10	15.4	20.4	25.8	35.8	49.8	59.3	79.3	92.3	102.3
D11 <sub>k6</sub>	62.9	72.9	87	107	103	127	158	178	198
D12	62	72	86	106	104	128	160	180	200
D13 <sub>k6</sub>	13	16	18	22	32	40	50	55	60
D14 <sub>H7</sub>	63	73	88	108	135	165	205	235	275
D16	M4	M5	M5	M8	M12	M16	M16	M16	M20
L1	65	75	90	110	140	170	210	240	280
L3	13	14.5	15	15	15	15	20	25	25
L4	2	2	2	2	2	2	2	2	2
L7	47.5	54	62	72	87	102	127	147	167
L11	27	30	36	44	55	67	85	95	110
L12	19.5	30	35	40	50	60	75	85	110

L13	13	15	15	15	15	15	20	25	25
L14	2	2	2	2	2	2	2	2	2
L15	16	25	28	32	45	50	70	80	100
L16	2	2.5	3.5	4	2.5	5	2.5	2.5	5
L17	6	8	8	8	10	10	10	10	10
L18	43	52.5	55	60	60	70	90	105	120
L19	4.5	4.8	4.8	7.2	10	12	12	12	15
L20	10	12.5	12.5	19	28	36	36	36	42
L21	75.5	90	100	115	130	155	195	225	260
L22	95	120	135	155	180	215	270	310	370
L23	40	47	55	60	70	80	95	115	130
L24	30	32	35	40	50	55	65	80	80
B2 <sub>h9</sub>	5	5	6	6	10	12	14	16	18
B3 <sub>p9</sub>	5	5	6	6	10	12	14	16	18
H2	15	18	20.5	24.5	35	43	53.5	59	64
H3	15.3	16.3	20.8	24.8	35.3	43.3	53.8	59.3	64.4