



# MOTOR MOUNTING INSTRUCTION

## Micro Planetary Gearbox Installation Manual

### » AM013 Assemble Procedures:

1. Check motor shaft runout.  $\sqrt{0.02A}$
2. Clean the grease or oil on motor shaft. Apply Loctite 638 on motor shaft (please see apply glue procedures).
3. Slide and rotate the sun gear on motor shaft.
4. Bolts the adapter on motor.
5. Put washer on adapter surface.
6. Screw the gearbox on adapter all the way and verify is seal tight.

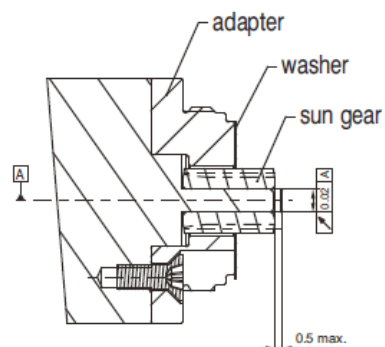

### » AM016 / 022 / 026 / 032 Assemble Procedures:

1. Check motor shaft runout.  $\sqrt{0.02A}$
2. Clean the grease or oil on motor shaft. Apply Loctite 638 on motor shaft (please see apply glue procedures).
3. Slide and rotate the sun gear on motor shaft.
4. Bolts the adapter on motor.
5. Put washer on adapter surface, check o-ring position.
6. Bolts the gearbox and motor together. Verify is seal tight.

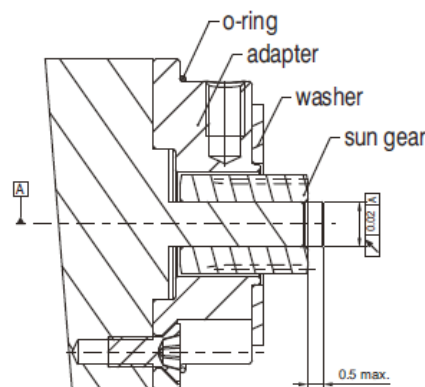

### » Apply Glue Procedures:

1. Check motor shaft and sun gear hole tolerance within 0.02mm. (sun gear hole tolerance is H7).
2. Clean the grease or oil in sun gear hole and motor shaft.
3. Sun gear can rotate or slide on motor shaft.
4. Minimum dry time for Loctite 638 is 4 hours. Keep the assembly in horizontal position.
5. After dried, under no-load test run for 15 minutes.