

# AT-4M serie

## Overzicht

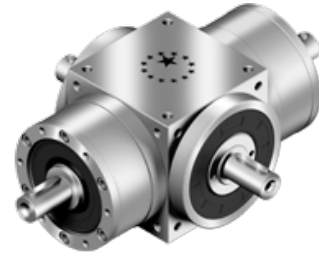

- Spiraal kegelwiel reductor met drie tandwielen van binnen. Alle vier de assen kunnen zowel als ingaande of als uitgaande as worden ingezet
- Roestvast stalen behuizing
- Roestvast stalen in- en uitgaande assen met of zonder spie
- Nominale koppels:
  - $T_{2N}$  : 12 Nm – 3.200 Nm
- Overbrengverhouding
  - 1-stage : 1
- Spelingarm
  - 1-traps :  $\leq 6$  arcmin
- Hoog rendement
  - 1-traps :  $\geq 98\%$
- Eenvoudige montage
- Compacte bouw
- Bouwgrootte: AT065 4M / AT075 4M / AT090 4M / AT110 4M / AT140 4M / AT170 4M / AT210 4M / AT240 4M / AT280 4M

# Specificaties

Bouwgrootte		Trap	Ratio <sup>1</sup>	AT065 4M	AT075 4M	AT090 4M	AT110 4M	AT140 4M	AT170 4M	AT210 4M	AT240 4M	AT280 4M
Nominaal uitgangskoppel $T_{2N}$	Nm	1	1	25	45	78	150	360	585	1,300	2,150	3,200
Max Versnellingskoppel $T_{2B}$	Nm	1	1	1.5 times Nominal Output Torque								
Max. Versnellings Ingangssnelheid $n_{iB}$	rpm	1	1	7,500	6,500	5,500	4,500	3,500	3,000	2,200	2,000	1,700
Verdraaispeling*	arcmin	1	1	≤ 6	≤ 6	≤ 6	≤ 6	≤ 6	≤ 6	≤ 6	≤ 6	≤ 6
Max. Radiale Last $F_{1rB2}$ Ingang d1	N	1	1	700	950	1,450	2,100	2,700	3,800	7,800	9,600	10,500
Max. Radiale Last $F_{2rB3}$ Uitgang d2	N	1	1	900	1,100	1,700	2,700	4,800	6,600	11,500	16,000	18,000
Max. Axiale Last $F_{1aB2}$ Ingang d1	N	1	1	350	425	725	1,050	1,350	1,900	3,900	4,800	5,250
Max. Axiale Last $F_{2aB3}$ Output d2	N	1	1	450	550	850	1,350	2,400	3,300	5,750	8,500	9,000
Service Life	hr	1	1	20,000*								
Efficiency	%	1	1	≥ 98 %								
Weight	kg	1	1	3.5	5.6	9.1	15.4	24.8	42.6	82.5	123.5	193.3
Operating Temp	°C	1	1	-10°C~+90°C								
Lubrication		1	1	Synthetic lubrication oils, ISO VG 150								
Noise Level ( $n_1=1500$ rpm, No Load)	dB(A)	1	1	≤68	≤70	≤74	≤76	≤77	≤78	≤80	≤82	≤83

1. Overbrengverhouding (ratio) (  $i=N_{in} / N_{out}$  )
2. Uitge oefend op het midden van de ingaande as @ 100 rpm
3. Uitge oefend op het midden van de uitgaande as @ 100 rpm

\* S1 service life 10,000 uren

\* Verdraaispeling is gemeten met 2% van het Nominaal koppel  $T_{2N}$

## Draairichting

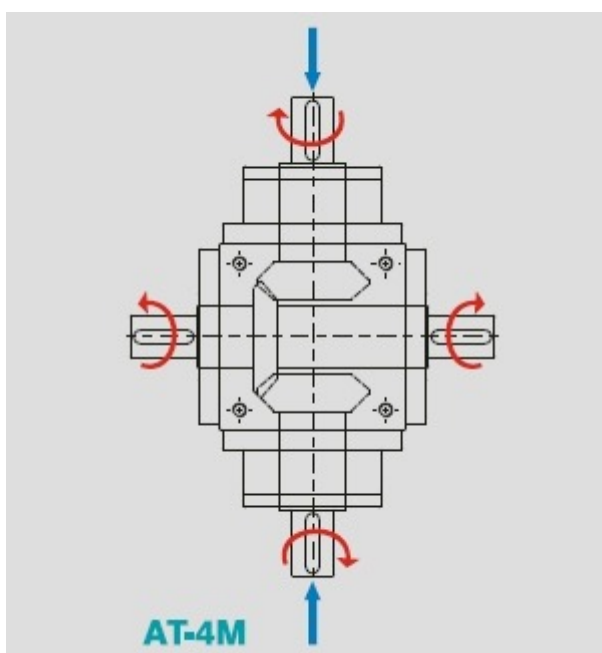

# Massatraagheid

Bouwgrootte		Trap	Ratio <sup>1</sup>	AT065 4M	AT075 4M	AT090 4M	AT110 4M	AT140 4M	AT170 4M	AT210 4M	AT240 4M	AT280 4M
Massatraagheid of inertia $J_1$	kg*cm <sup>2</sup>	1	1	0.51	1.30	3.16	7.70	23.57	58.99	195.40	369.34	799.12

# Afmetingen

## AT-4M serie 1-traps

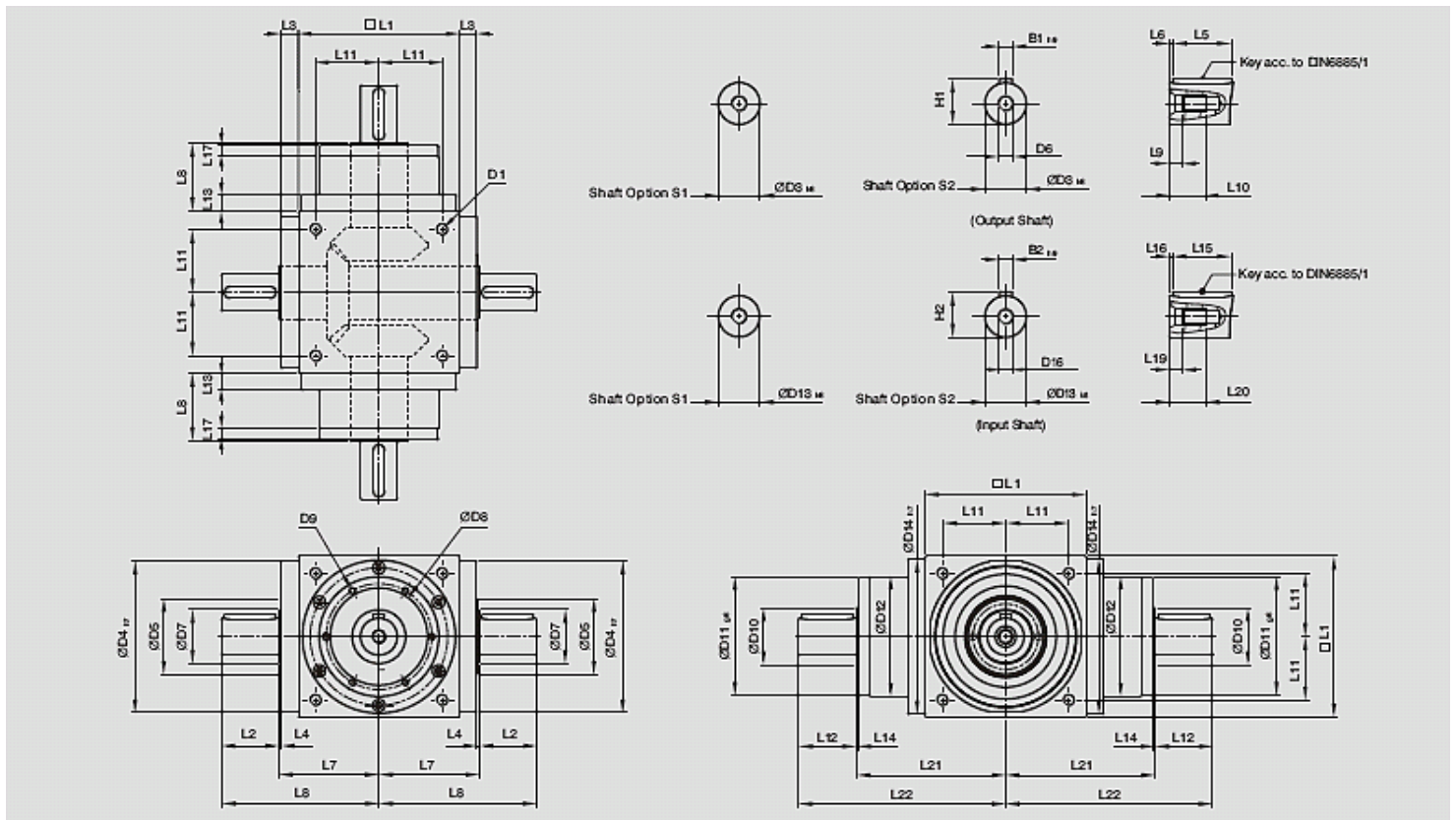

	AT065 4M	AT075 4M	AT090 4M	AT110 4M	AT140 4M	AT170 4M	AT210 4M	AT240 4M	AT280 4M
D1	M4	M6	M6	M8	M10	M12	M16	M16	M16
D3 <sub>k6</sub>	13	16	18	22	32	40	50	55	60
D4 <sub>h7</sub>	63	73	88	108	135	165	205	235	275
D5	31	35	43	53	68	83	104	124	144
D6	M4	M5	M5	M8	M12	M16	M16	M16	M20
D7	21	22	28	33	47	55	75	85	110
D8	53	62	76	95	92	114	142	160	176
D9	4xM4xL7	4xM5xL8	4xM5xL8	6xM6xL10	6xM6xL10	6xM8xL12.5	6xM8xL12.5	6xM8xL12.5	6xM10xL15
D10	15.4	20.4	25.8	35.8	49.8	59.3	79.3	92.3	102.3
D11 <sub>g6</sub>	62.9	72.9	87	107	103	127	158	178	198
D12	62	72	86	106	104	128	160	180	200
D13 <sub>k6</sub>	13	16	18	22	32	40	50	55	60
D14 <sub>h7</sub>	63	73	88	108	135	165	205	235	275
D16	M4	M5	M5	M8	M12	M16	M16	M16	M20
L1	65	75	90	110	140	170	210	240	280
L2	19.5	30	35	40	50	60	75	85	110
L3	13	14.5	15	15	15	15	20	25	25
L4	2	2	2	2	2	2	2	2	2
L5	16	25	28	32	45	50	70	80	100
L6	2	2.5	3.5	4	2.5	5	2.5	2.5	5
L7	47.5	54	62	72	87	102	127	147	167
L8	67	84	97	112	137	162	202	232	277
L9	4.5	4.8	4.8	7.2	10	12	12	12	15
L10	10	12.5	12.5	19	28	36	36	36	42
L11	27	30	36	44	55	67	85	95	110
L12	19.5	30	35	40	50	60	75	85	110
L13	13	15	15	15	15	15	20	25	25

L14	2	2	2	2	2	2	2	2	2
L15	16	25	28	32	45	50	70	80	100
L16	2	2.5	3.5	4	2.5	5	2.5	2.5	5
L17	6	8	8	8	10	10	10	10	10
L18	43	52.5	55	60	60	70	90	105	120
L19	4.5	4.8	4.8	7.2	10	12	12	12	15
L20	10	12.5	12.5	19	28	36	36	36	42
L21	75.5	90	100	115	130	155	195	225	260
L22	95	120	135	155	180	215	270	310	370
B1 <sub>h9</sub>	5	5	6	6	10	12	14	16	18
B2 <sub>h9</sub>	5	5	6	6	10	12	14	16	18
H1	15	18	20.5	24.5	35	43	53.5	59	64
H2	15	18	20.5	24.5	35	43	53.5	59	64