

AH series

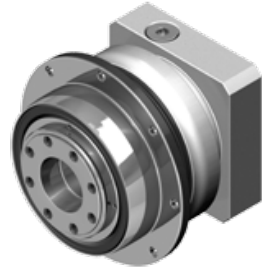

Overview

- Heavy Duty gearbox
- Black coated steel housing and output flange, aluminum motor adapter
- Steel output shaft, flange ISO 9409
- Helical gear technology
- Nominal Torques:
 - T_{2N} : 24 Nm – 10.915 Nm
- Ratios
 - 1-stage : 4 / 5 / 7 / 10
 - 2-stage : 16 / 20 / 21 / 25 / 28 / 31 / 35 / 40 / 46 / 50 / 61 / 70 / 91 / 100
- Low Backlash
 - 1-stage : ≤ 1 arcmin (size 064 ≤ 2 arcmin)
 - 2-stage : ≤ 2 arcmin (size 064 ≤ 3 arcmin)
- High Efficiency
 - 1-stage : $\geq 97\%$
 - 2-stage : $\geq 94\%$
- Easy mount
- Low noise
- Compact structure
- Sizes available: AH064 / AH090 / AH110 / AH140 / AH200 / AH255 / AH285 / AH355 / AH450

Specifications

Model No.	Stage	Ratio ¹	AH064	AH090	AH110	AH140	AH200	AH255	AH285	AH355	AH450
Nominal output torque T_{2N} Nm	1	4	95	195	350	600	1.290	-	-	-	-
		5	80	165	305	525	1.145	1.745	3.285	-	-
		7	60	130	250	435	980	1.495	2.525	-	-
		10	24	55	160	305	700	1.070	1.810	-	-
		16	95	195	360	615	1.320	-	-	-	-
		20	95	200	360	615	1.320	1.770	3.325	-	-
		21	80	165	310	535	1.165	1.770	3.330	5.595	10.915
	25	80	165	310	535	1.165	1.770	3.330	-	-	
	28	60	200	360	615	1.325	-	-	-	-	
	31	60	130	250	440	990	1.510	2.550	4.810	9.565	
	35	70	170	310	535	1.165	1.775	3.335	-	-	
	40	40	96	220	615	1.215	-	-	-	-	
	46	24	55	160	295	660	1.005	1.700	3.400	7.125	
	50	50	120	275	535	1.170	1.775	3.340	-	-	
	61	60	130	250	440	990	1.510	2.550	4.820	9.585	
	70	60	130	250	440	990	1.510	2.550	-	-	
	91	24	55	160	295	660	1.005	1.700	3.345	7.000	
100	24	55	160	295	660	1.005	1.700	-	-		
Emergency stop torque T_{2NOT} Nm ⁽³⁾	1,2	4~100	3 times nominal output torque T_{2N}								
Max. Acceleration torque T_{2B} Nm	1,2	4~100	1,5 times nominal output torque T_{2N}								
No load running torque ⁽³⁾ Nm	1	4~10	0,45	0,7	1,4	3,5	7	11	14	-	-
	2	16~100	0,2	0,3	0,6	1,3	2,2	3,5	4,5	13	21
Backlash ⁽²⁾ arcmin	1	4~10	≤ 2	≤ 1	≤ 1	≤ 1	≤ 1	≤ 1	≤ 1	≤ 1	≤ 1
	2	16~100	≤ 3	≤ 2	≤ 2	≤ 2	≤ 2	≤ 2	≤ 2	≤ 2	≤ 2
Torsional rigidity Nm/arcmin	1,2	4~100	8	22	60	115	395	650	1.050	2.850	5.700
Nominal input speed N_{1N} rpm	1	4~10	5.000	3.600	3.600	3.000	2.700	2.400	2.100	-	-
	2	16~100	5.000	4.600	4.600	4.000	3.700	3.400	3.100	2.500	2.000
Max. input speed N_{1B} rpm	1	4~10	7.000	6.000	6.000	5.000	4.500	4.000	3.500	-	-
	2	16~100	7.000	7.000	7.000	6.000	5.500	5.000	4.500	4.000	3.500
Max. radial load F_{2a} N	1,2	4~100	1.690	2.220	4.070	8.530	17.000	26.900	39.200	101.500	143.700
Max. Bending moment M_{2k} Nm	1,2	4~100	120	280	480	1.310	3.530	5.920	9.230	29.100	63.300
Service Life ⁽⁴⁾ hr	1,2	4~100	20,000								
Operating temperature °C	1,2	4~100	-10°C ~+ 90°C								
Degree of Protection	1,2	4~100	IP65								
Lubrication	1,2	4~100	Synthetisch lubrication grease (NYOGEL 792D)								
Mounting position	1,2	4~100	All directions								
Running noise ($n_1=3000$ rpm, No Load) dB(A)	1	4~10	≤ 58	≤ 59	≤ 64	≤ 65	≤ 66	≤ 66	≤ 66	-	-
	2	16~100	≤ 58	≤ 59	≤ 60	≤ 63	≤ 66	≤ 66	≤ 66	≤ 68	≤ 70
Efficiency %	1	4~10	≥ 97 %								
	2	16~100	≥ 94 %								

(1) Ratio ($i = N_{in} / N_{out}$)

(2) Backlash is measured at 2% of Nominal output torque T_{2N} .

(3) These values are measured by gearbox with ratio = 10 (1-stage) or ratio = 100 (2-stage) at 3.000 rpm without load.

(4) Continuous operation (S1) is not recommended.

Inertia

Model No.	AH064		AH090		AH110		AH140		AH200		AH255		AH285		AH355	AH450
	1-st.	2-st.	1-st.	2-st.	1-st.	2-st.	1-st.	2-st.	1-st.	2-st.	1-st.	2-st.	1-st.	2-st.	2-st.	2-st.
8	-	0,10	-	-	-	-	-	-	-	-	-	-	-	-	-	-
11	0,17	0,16	-	0,17	-	-	-	-	-	-	-	-	-	-	-	-
14	0,21	0,20	0,53	0,21	-	0,53	-	-	-	-	-	-	-	-	-	-
19	0,63	-	0,68	0,63	1,83	0,68	-	1,83	-	-	-	-	-	-	-	-
24	-	-	4,52	-	5,04	4,52	5,63	5,04	-	5,63	-	-	-	-	-	-
28	-	-	-	-	6,33	-	7,18	6,33	-	7,18	-	-	-	-	-	-
32	kg*cm ²	-	-	-	8,73	-	10,10	8,73	12,63	10,10	-	12,63	-	-	-	-
35	-	-	-	-	14,04	-	15,54	14,04	17,75	15,54	17,35	17,75	28,18	20,80	-	-
38	-	-	-	-	19,05	-	21,35	19,05	23,26	21,32	23,61	23,26	28,18	27,05	23,60	-
42	-	-	-	-	-	-	23,20	-	25,40	23,20	25,50	25,40	30,52	28,95	25,37	30,37
48	-	-	-	-	-	-	56,07	-	61,02	56,07	61,22	61,02	66,85	64,66	89,35	96,45
55	-	-	-	-	-	-	-	-	-	-	88,86	-	94,91	-	102,00	109,06
60	-	-	-	-	-	-	-	-	-	-	-	-	117,73	-	-	117,75

(A) \varnothing = Input shaft diameter

Sizes

AH series:

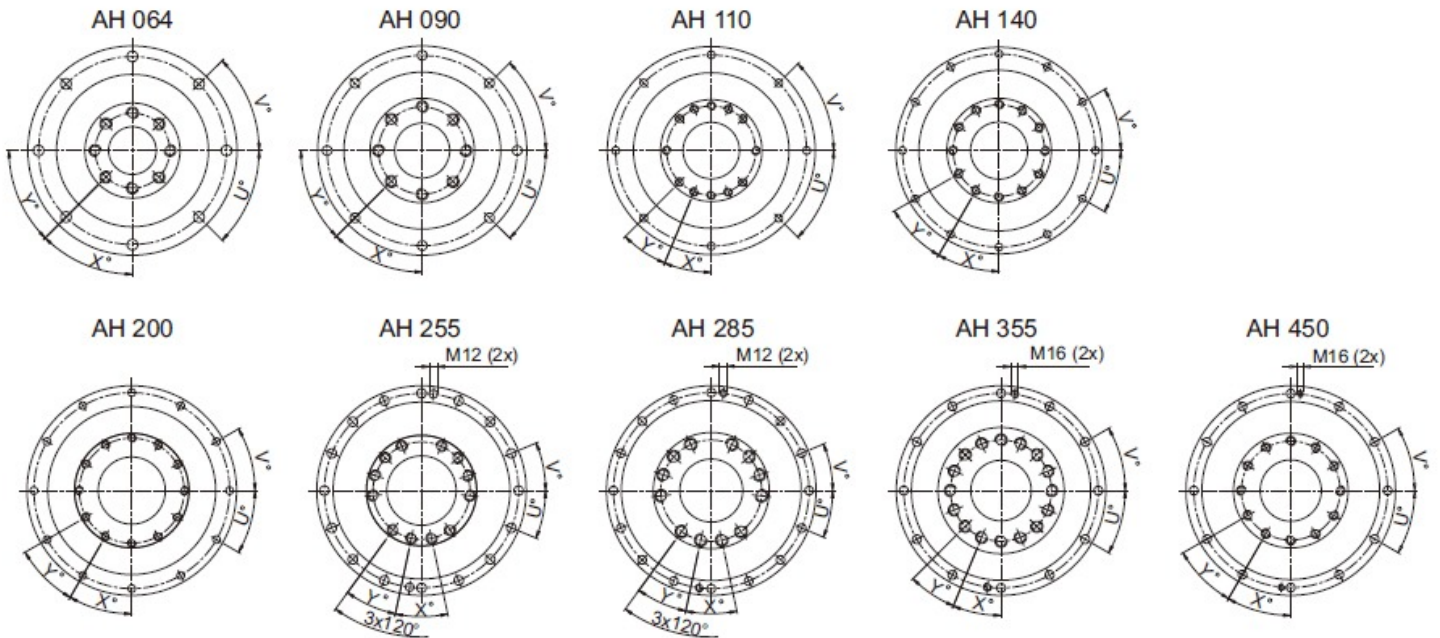
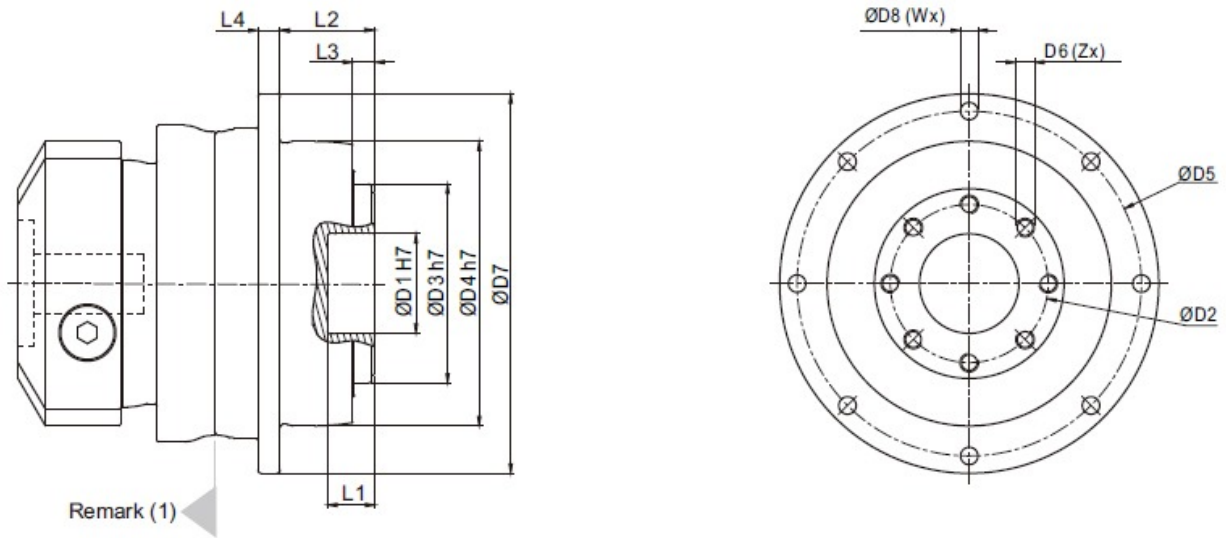

Afmeting	AH064	AH090	AH110	AH140	AH200	AH255	AH285	AH355	AH450
D1 H7	20	31,5	40	50	80	100	100	120	155
D2	31,5	50	63	80	125	140	160	200	250
D3 h7	40	63	80	100	160	180	200	250	315
D4 h7	64	90	110	140	200	255	285	355	450
D5	79	109	135	168	233	280	310	385	490
D6 x spoed x diepte	M5 x 0,8P x 8	M6 x 1P x 10	M6 x 1P x 11	M8 x 1,25P x 15	M10 x 1,5P x 20	M16 x 2P x 25	M20 x 2,5P x 31	M24 x 3P x 32	M30 x 3,5P x 40
D7	88	120	147	180	249,5	302	332	415	530
D8	4,5	5,5	5,5	6,6	9	13,5	13,5	17,5	22
L1	8	15	15	15	16	16	16	35	24
L2	19,5	30	29	38	50	66	75	80	85
L3	4	7	7	7,5	8,5	13,5	16,5	20	20
L4	5	7	8	10	12	18	20	45	60
X in graden	45	45	22,5	30	30	24	24	22,5	30
Y in graden	45	45	22,5	30	30	24	24	22,5	30
Z	8	8	12	12	12	12	12	16	12

U in graden	45	45	45	30	30	22,5	22,5	30	30
V graden	45	45	45	30	30	22,5	22,5	30	30
W	8	8	8	12	12	16	16	12	12

(1) Input dimensions vary according to motor flange. Please contact Apex Dynamics for details.

Flange As - AH series:

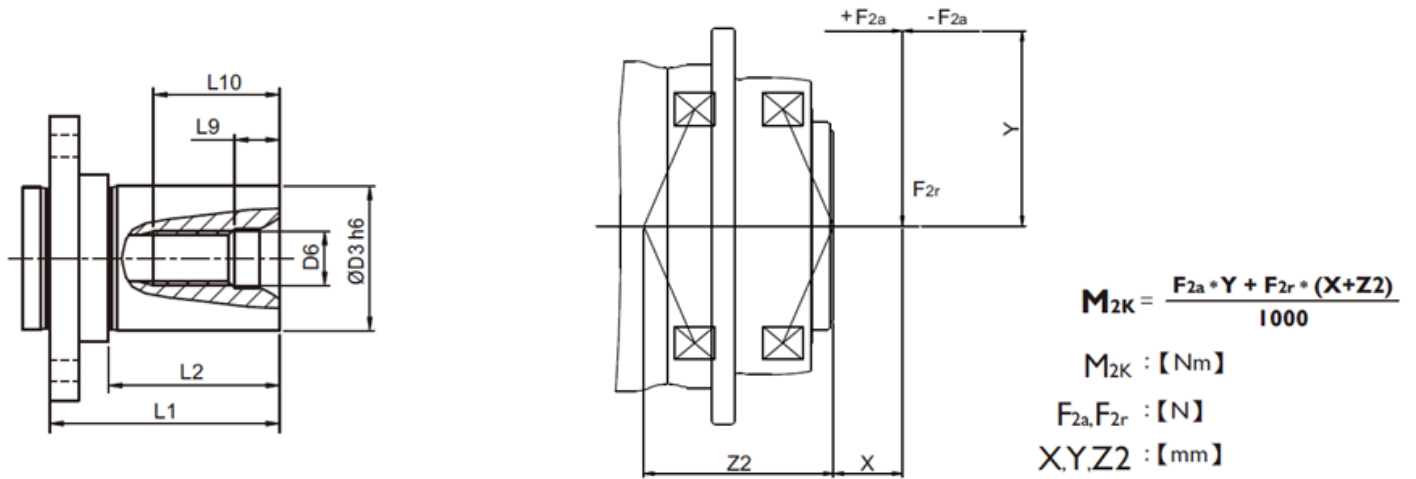

Afmeting L1 L2 $\frac{D3}{h6}$ D6 L9 L10 Order Coder

16 M5 4,812,5FLS-AH064-S16

AH064 33 23

22 M8 7,2 19 FLS-AH064-S22

22 M8 7,2 19 FLS-AH090-S22

AH090 41 30

32M1210 28 FLS-AH090-S32

32M1210 28 FLS-AH110-S32

AH110 51 38

40M1612 36 FLS-AH110-S40

40M16 12 36 FLS-AH140-S40

AH0140 54 38

55M20 15 42 FLS-AH140-S55

55M20 15 42 FLS-AH200-S55

AH200 73 52

75M20 15 42 FLS-AH200-S75

AH255 15012390M24 18 50 FLS-AH255-S90