

KF-S2 spiral bevel series

Overview

- Black coated steel housing, aluminum output and motor adapter flange
- Steel output shaft, with key-way
- Spiral bevel gear design
- Nominal torques:
 - T_{2N} : 24 Nm – 1.300 Nm
- Ratios
 - 1-stage : 1 / 2
- Low backlash
 - 1-stage : ≤ 3 arcmin
- High efficiency
 - 1-stage : $\geq 97\%$
- Easy mount
- High accuracy
- The output shaft rotates in the same direction as the servomotor
- Available sizes: KF060 / KF075 / KF100 / KF140 / KF180 / KF210 / KF240



Specifications

KF		Stage	Ratio ⁽¹⁾	KF 060	KF 075	KF 100	KF 140	KF 180	KF 210	KF 240
Nominal output torque T_{2N}	Nm	1	1	25	45	78	150	360	585	1.300
			2	24	42	68	150	330	544	1.220
Emergency stop torque T_{2NOT}	Nm	1	1	2 times of nominal torque T_{2N}						
Max. Acceleration torque T_{2B}	Nm	1	1-2	1,5 times of nominal torque T_{2N}						
No load running torque ⁽⁴⁾	Nm	1	1-2	0.3	0.3	1.5	1.7	5.5	9	20
Backlash ⁽²⁾	arcmin	1	1-2	≤3	≤3	≤3	≤3	≤3	≤3	≤3
Torsional rigidity	Nm/arcmin	1	1-2	0.8	3.5	9	20.5	44	80	168
Nominal input speed n_{1N}	rpm	1	1-2	6,500	4,500	3,500	2,000	1,500	1,200	1,000
Max. input speed n_{1B}	rpm	1	1-2	7.500	6,500	5,500	4,500	3,500	3,000	2,200
Max. radial load F_{2rB} ⁽³⁾	N	1	1-2	5,400	7,700	11,100	15,100	26,100	36,400	46,900
Max. axial load F_{2aB} ⁽³⁾	N	1	1-2	2,700	3,850	5,550	9,050	14,550	18,200	23,450
Operating temperature	°C	1	1-2	0° C ~ +90°C						
Degree of Protection		1	1-2	IP65						
Lubrication		1	1-2	Synthetisch lubrication grease						
Mounting position		1	1-2	All directions						
Running noise ⁽⁴⁾	dB (A)	1	1-2	≤68	≤70	≤74	≤76	≤77	≤78	≤80
Efficiency η	%	1	1-2	≥97%						

- (1) Ratio ($i = N_{in} / N_{out}$)
- (2) Backlash is measured at 2% of Nominal output torque T_{2N} .
- (3) Applied to the output shaft center @ 100 rpm .
- (4) These values are measured by gearbox with ratio = 10 (1-stage) or ratio = 100 (2-stage) at 3.000 rpm without load.

Permitted Radial And Axial Loads

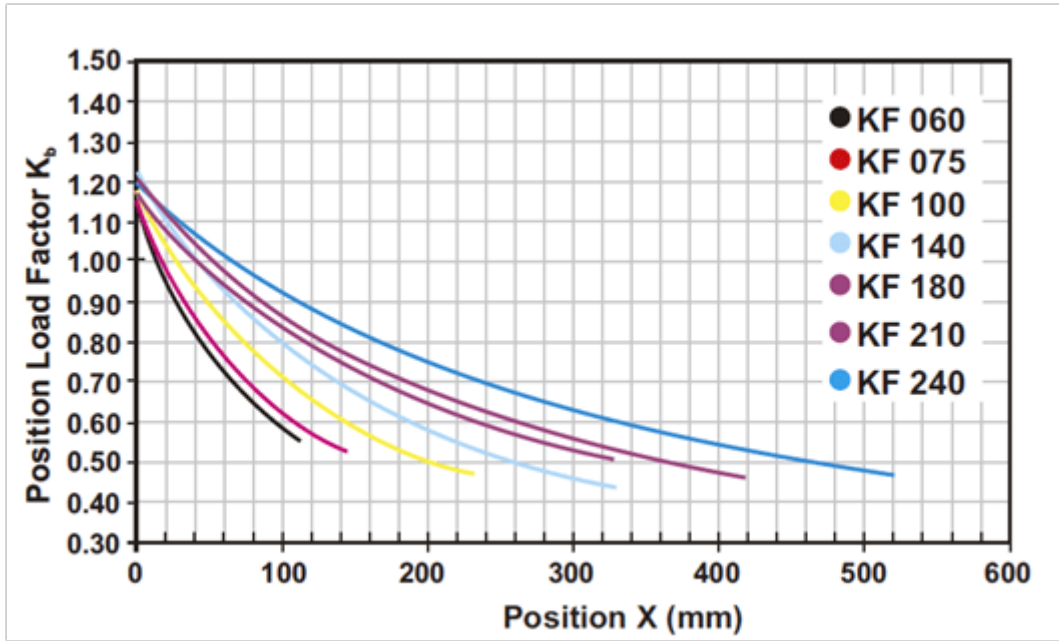

If radial force F_{2r} is not exerted on the center of the output shaft $X < \frac{1}{2} \times L$ or $X > \frac{1}{2} \times L$, the permitted radial and axial loads can be calculated by the position load factor K_b on the above diagram.

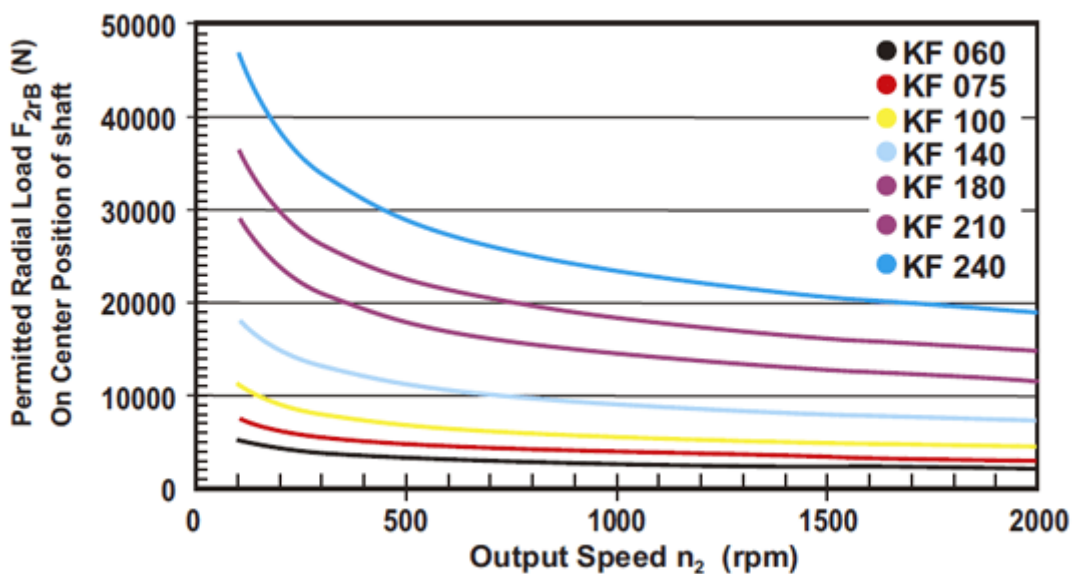

Permitted radial load F_{2r} on center of output shaft $X = \frac{1}{2} \times L$ for various output speeds. Values provided are for 20.000 hours life.

(A) Ø Input shaft diameter

(B) Permitted loading values on the output shaft. Please contact Apex Dynamics for more details.

Inertia

Model No.	KF 060	KF 075	KF 100	KF 140	KF 180	KF 210	KF 240
Ø ^(A) (C3)	1-stage	1-stage	1-stage	1-stage	1-stage	1-stage	1-stage
8	0.10	-	-	-	-	-	-
11	0.17	0.18	-	-	-	-	-
14	0.21	0.50	-	-	-	-	-
19	0.62	0.63	1.69	-	-	-	-
24	-	4.49	4.89	5.05	-	-	-
28	-	-	6.14	6.55	-	-	-
32 ₂ ^{kg*cm}	-	-	8.54	9.47	10.18	-	-
35	-	-	13.86	14.91	15.21	15.68	23.46
38	-	-	18.87	20.69	20.7	21.69	23.46
42	-	-	-	22.58	22.83	23.59	25.28
48	-	-	-	55.45	58.45	25.40	61.61
55	-	-	-	-	-	61.02	89.67
60	-	-	-	-	-	-	112.49

(A) Ø Input shaft diameter

Sizes

KF-S1 / S2 -spiral bevel:

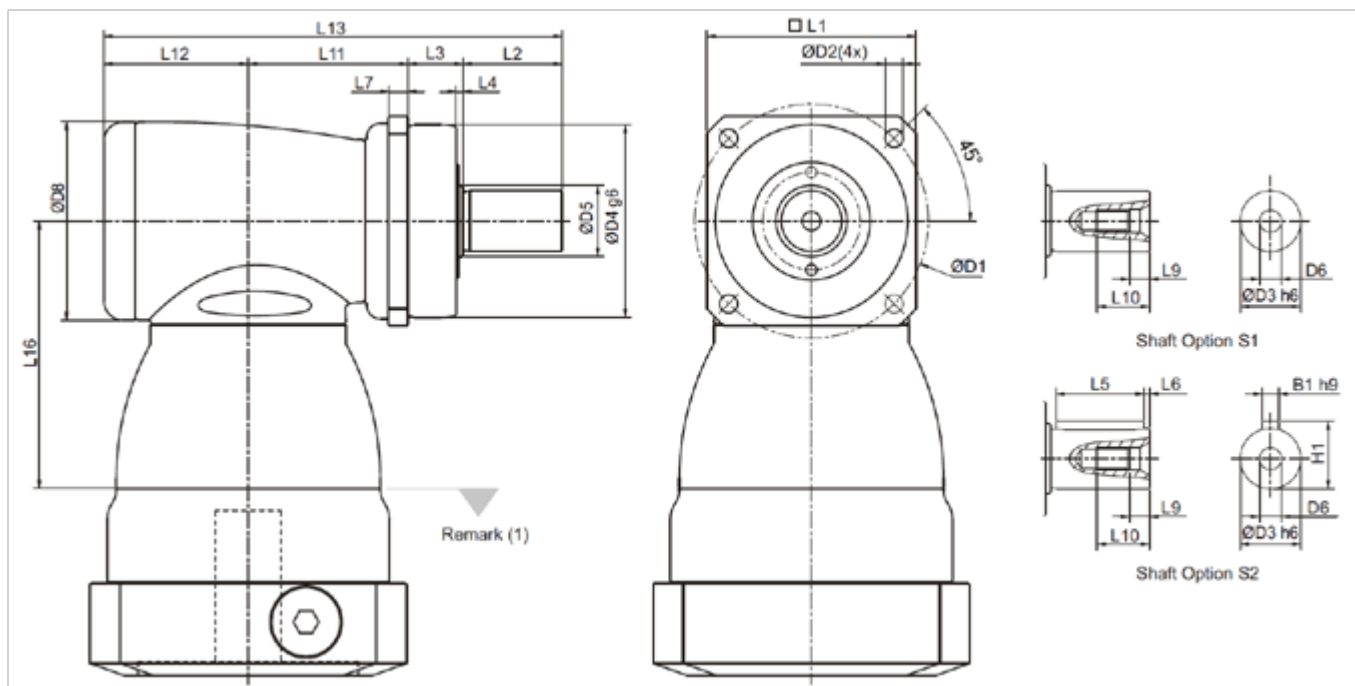

	KF 060	KF 075	KF 100	KF 140	KF 180	KF 210	KF 240
	1-stage	1-stage	1-stage	1-stage	1-stage	1-stage	1-stage
D1	68	85	120	165	215	250	290
D2	5,5	6,6	9	11	13,5	17	17
D3 h6	16	22	32	40	55	75	85
D4 g6	60	70	90	130	160	180	200
D5	18,5	25,8	36,8	55,2	69,2	82,2	92,2
D6	M5x0,8P	M8x1,25P	M12x1,75P	M16x2P	M20x2,5P	M20x2,5P	M20x2,5P
D8	64	72	92	116	156	195	240
L1	62	76	101	141	182	215	245
L2	28	36	58	82	82	105	130
L3	20	20	30	30	30	38	40
L4	2	2,5	3	3	3	3	3
L5	25	32	50	63	70	90	125
L6	2	2	4	5	6	7	3
L7	6	7	10	12	15	17	20
L9	4,8	7,2	10	12	15	15	15
L10	12,5	19	28	36	42	42	42
L11	50	58	67,5	88	127	131,5	169
L12	46,5	52,5	61,5	76	97,5	105,5	141
L13	144,5	166,5	217	276	336,5	380	480
L16	81,5	97	113,5	147,5	196,5	229	260

B1 h9	5	6	10	12	16	20	22
H1	18	24,5	35	43	59	79,5	90

(1) Dimensions are related to motor interface. Please contact Apex Dynamics for details.