

Motor mounting instruction ATB series 1-Stage

1



Double-check the motor and gearbox size.
Clean the mounting surface

2



Remove the plug on the adapter plate.
Rotate the set collar till the bolt lines up.

3

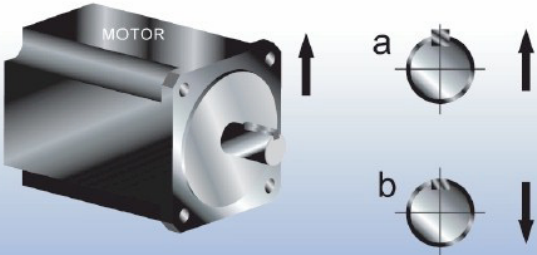

a. Remove the motor key
b. Insert balance key if necessary

4

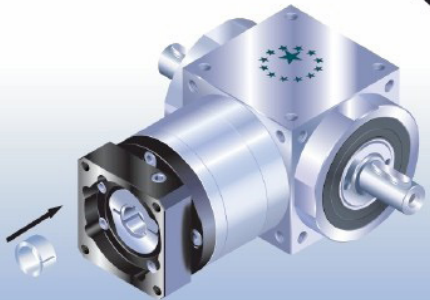

Check motor shaft size and insert bushing if necessary

✓ Correct Installation

When installing on flatted shafts, be sure to align the collet gap over the flat and the set collar bolt perpendicular to the flat

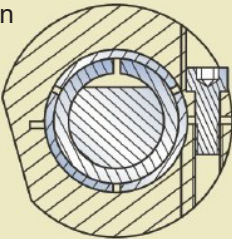

5



Set at vertical position, tighten the mounting bolts (including washer) in 1 - 4 order with wrench to 5% specified torque (see table 1)

6

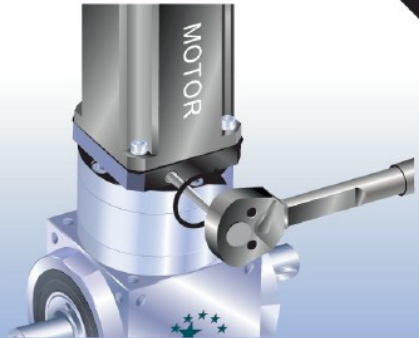

Tighten the set collar bolt with torque wrench to specified torque (see table 2)

7



Tighten the mounting bolts in 1 - 4 order with torque wrench to specified torque (see table 1)

8



Tighten back the screw plug

Table 1 Tightening torque recommended for motor mounting bolt

Bolt size	Width across flat	Strength 8.8 Tightening torque		Strength 10.9 Tightening torque		Strength 12.9 Tightening torque	
	[mm]	[Nm]	[In-lbs]	[Nm]	[In-lbs]	[Nm]	[In-lbs]
M3 x 0.5P	2.5	1.3	12	1.8	16	2.1	19
M4 x 0.7P	3	3	27	4.1	37	4.9	44
M5 x 0.8P	4	6.1	55	8.2	73	9.8	87
M6 x 1P	5	11	98	14	124	17	151
M8 x 1.25P	6	25	222	34	302	41	364
M10 x 1.5P	8	49	434	67	594	80	709
M12 x 1.75P	10	85	753	116	1028	139	1232
M14 x 2P	12	137	1214	186	1648	223	1976
M16 x 2P	14	210	1860	286	2534	343	3038

Table 2 Tightening torque recommended for set collar bolt

Gearbox size		Motor shaft diameter	Bolt size	Width across flats	Tightening torque	
		[mm]	[mm]	[mm]	[Nm]	[In-lbs]
ATB065	1-Stage	≤ 11	M3 x 0.5P x 8L	2.5	2.1	19
ATB075	1-Stage	≤ 14	M4 x 0.7P x 12L	3	4.9	44
ATB090	1-Stage	≤ 19	M5 x 0.8P x 14L	4	9.8	87
ATB110	1-Stage	≤ 24	M5 x 0.8P x 14L	4	9.8	87
ATB140	1-Stage	≤ 32	M6 x 1P x 16L	5	17	151
ATB170	1-Stage	≤ 38	M8 x 1.25P x 20L	6	41	364
ATB210	1-Stage	≤ 42	M10 x 1.5P x 25L	8	80	709
ATB240	1-Stage	≤ 48	M10 x 1.5P x 25L	8	80	709
ATB280	1-Stage	≤ 55	M12 x 1.75P x 30L	10	139	1232

Note: Bolts can be tightened up to 20% higher for increased holding torques

Apex Dynamics BV

Churchillaan 101
5705 BK Helmond
The Netherlands

Tel. : +31 (0)492 509 995
E-mail: sales@apexdyna.nl
Web : www.apexdyna.nl



Motor mounting instruction ATB series 2/3-Stage

1

Double-check the motor and gearbox size.
Clean the mounting surface

2

a. Remove the motor key
b. Insert balance key if necessary

3

Check motor shaft size and insert bushing if necessary

Correct Installation

When installing on flatted shafts, be sure to align the collet gap over the flat and the set collar bolt perpendicular to the flat

4

Set at vertical position, tighten the mounting bolts (including washer) in 1 - 4 order with wrench to 5% specified torque (see table 1)

5

Tighten the set collar bolt with torque wrench to specified torque (see table 2)

6

Tighten the mounting bolts in 1 - 4 order with torque wrench to specified torque (see table 1)

7

Tighten back the screw plug



Table 1 Tightening torque recommended for motor mounting bolt

Bolt size	Width across flat	Strength 8.8 Tightening torque		Strength 10.9 Tightening torque		Strength 12.9 Tightening torque	
	[mm]	[Nm]	[In-lbs]	[Nm]	[In-lbs]	[Nm]	[In-lbs]
M3 x 0.5P	2.5	1.3	12	1.8	16	2.1	19
M4 x 0.7P	3	3	27	4.1	37	4.9	44
M5 x 0.8P	4	6.1	55	8.2	73	9.8	87
M6 x 1P	5	11	98	14	124	17	151
M8 x 1.25P	6	25	222	34	302	41	364
M10 x 1.5P	8	49	434	67	594	80	709
M12 x 1.75P	10	85	753	116	1028	139	1232
M14 x 2P	12	137	1214	186	1648	223	1976
M16 x 2P	14	210	1860	286	2534	343	3038

Table 2 Tightening torque recommended for set collar bolt

Gearbox size		Motor shaft diameter	Bolt size	Width across flats	Tightening torque	
		[mm]	[mm]	[mm]	[Nm]	[In-lbs]
ATB065	2-Stage	≤ 12	M6 x 1P x 8L	3	5.6	50
ATB075	2-Stage	≤ 12	M6 x 1P x 8L	3	5.6	50
ATB090	2-Stage	≤ 16	M8 x 1.25P x 10L	4	9.5	85
ATB110	2-Stage	≤ 24	M10 x 1.5P x 12L	5	23	205
	3-Stage	≤ 12	M6 x 1P x 8L	3	5.6	50
ATB140	2-Stage	≤ 24	M10 x 1.5P x 12L	5	23	205
	3-Stage	≤ 12	M6 x 1P x 8L	3	5.6	50
ATB170	2-Stage	≤ 24	M10 x 1.5P x 12L	5	23	205
	3-Stage	≤ 16	M8 x 1.25P x 10L	4	9.5	85
ATB210	2-Stage	≤ 32	M12 x 1.75P x 16L	6	45	400
	3-Stage	≤ 16	M8 x 1.25P x 10L	4	9.5	85
ATB240	2-Stage	≤ 38	M16 x 2P x 20L	8	78	693
	3-Stage	≤ 24	M10 x 1.5P x 25L	5	23	205
ATB280	2-Stage	≤ 38	M16 x 2P x 20L	8	78	693
	3-Stage	≤ 24	M10 x 1.5P x 25L	5	23	205

Note: Bolts can be tightened up to 20% higher for increased holding torques

Apex Dynamics BV

Churchillaan 101
5705 BK Helmond
The Netherlands

Tel. : +31 (0)492 509 995
E-mail: sales@apexdyna.nl
Web : www.apexdyna.nl