

Motor mounting instruction PGIIR series

1

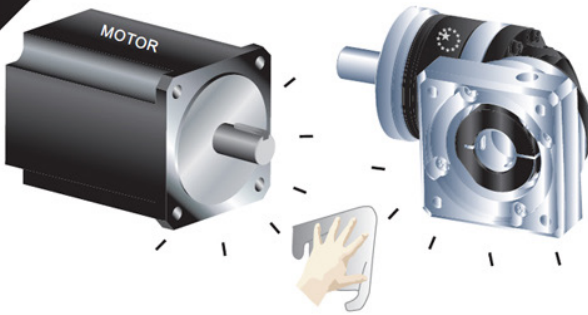

Double-check the motor and gearbox size.
Clean the mounting surface

2

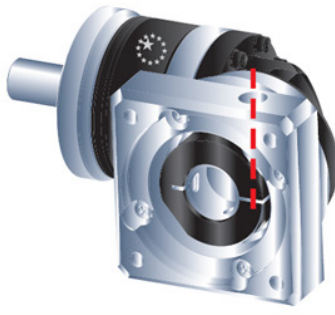

Remove the plug on the adapter plate.
Rotate the set collar till the bolt lines up.

3

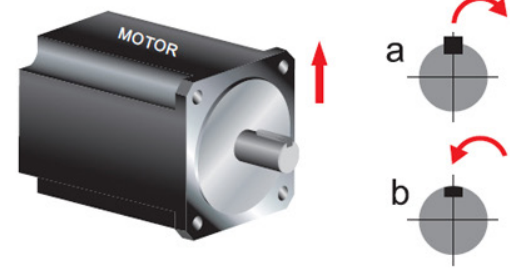

a. Remove the motor key
b. Insert balance key if necessary

4

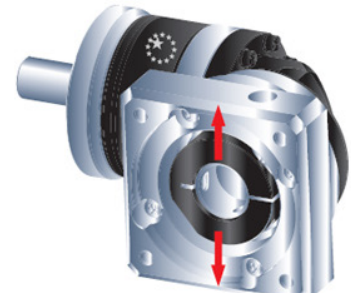

Check motor shaft size and insert bushing if necessary

✓ Correct Installation

When installing on flatted shafts, be sure to align the collet gap over the flat and the set collar bolt perpendicular to the flat

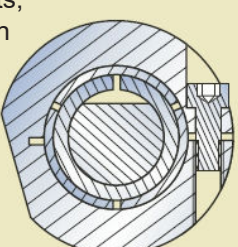

5

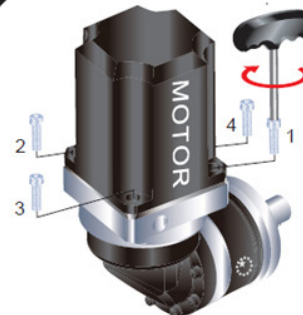

Set at vertical position, tighten the mounting bolts (including washer) in 1 - 4 order with wrench to 5% specified torque (see table 1)

6

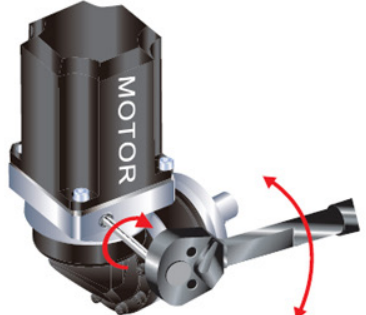

Tighten the set collar bolt with torque wrench to specified torque (see table 2)

7

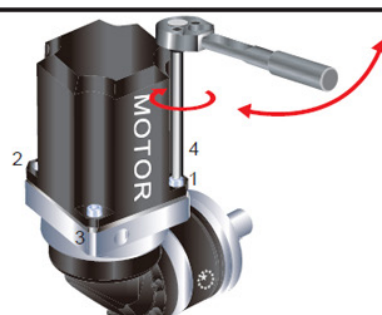

Tighten the mounting bolts in 1 - 4 order with torque wrench to specified torque (see table 1)

8



Tighten back the screw plug



Table 1 Tightening torque recommended for motor mounting bolt

Bolt size	Width across flat	Strength 8.8 Tightening torque		Strength 10.9 Tightening torque		Strength 12.9 Tightening torque	
	[mm]	[Nm]	[In-lbs]	[Nm]	[In-lbs]	[Nm]	[In-lbs]
M3 x 0.5P	2.5	1.3	12	1.8	16	2.1	19
M4 x 0.7P	3	3	27	4.1	37	4.9	44
M5 x 0.8P	4	6.1	55	8.2	73	9.8	87
M6 x 1P	5	11	98	14	124	17	151
M8 x 1.25P	6	25	222	34	302	41	364
M10 x 1.5P	8	49	434	67	594	80	709
M12 x 1.75P	10	85	753	116	1028	139	1232
M14 x 2P	12	137	1214	186	1648	223	1976
M16 x 2P	14	210	1860	286	2534	343	3038

Table 2 Tightening torque recommended for set collar bolt

Gearbox size	Motor shaft diameter	Bolt size	Width across flats	Tightening torque	
	[mm]	[mm]	[mm]	[Nm]	[In-lbs]
PGIIR040	≤ 8	M5 x 0.8P x 16L	4	9.8	87
	≤ 11	M5 x 0.8P x 16L	4	9.8	87
	≤ 14	M5 x 0.8P x 16L	4	9.8	87
PGIIR060	≤ 8	M5 x 0.8P x 16L	4	9.8	87
	≤ 11	M5 x 0.8P x 16L	4	9.8	87
	≤ 14	M5 x 0.8P x 16L	4	9.8	87
	≤ 19	M8 x 1.25P x 25L	6	41	364
PGIIR080	≤ 14	M5 x 0.8P x 16L	4	9.8	87
	≤ 19	M8 x 1.25P x 25L	6	41	364
	≤ 24	M8 x 1.25P x 25L	6	41	364
	≤ 28	M8 x 1.25P x 25L	6	41	364
PGIIR120	≤ 19	M8 x 1.25P x 25L	6	41	364
	≤ 24	M8 x 1.25P x 25L	6	41	364
	≤ 28	M8 x 1.25P x 25L	6	41	364
	≤ 32	M10 x 1.5P x 25L	8	80	709
	≤ 35	M10 x 1.5P x 25L	8	80	709
	≤ 38	M10 x 1.5P x 25L	8	80	709
PGIIR160	≤ 19	M8 x 1.25P x 25L	6	41	364
	≤ 24	M8 x 1.25P x 25L	6	41	364
	≤ 28	M8 x 1.25P x 25L	6	41	364
	≤ 32	M10 x 1.5P x 25L	8	80	709
	≤ 35	M10 x 1.5P x 25L	8	80	709
	≤ 38	M10 x 1.5P x 25L	8	80	709
	≤ 42	M12 x 1.75P x 30L	10	139	1232

Note: Bolts can be tightened up to 20% higher for increased holding torques

Apex Dynamics BV

Churchillaan 101
5705 BK Helmond
The Netherlands

Tel. : +31 (0)492 509 995
E-mail: sales@apexdyna.nl
Web : www.apexdyna.nl