

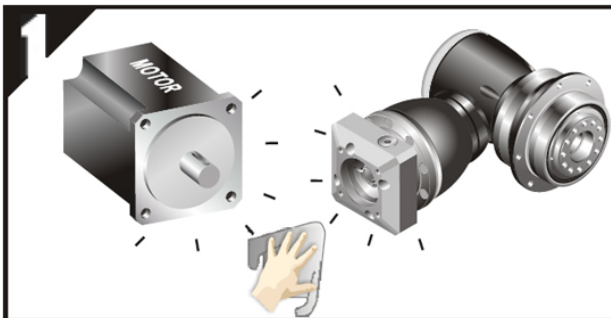

MOTOR ANBAU ANLEITUNG

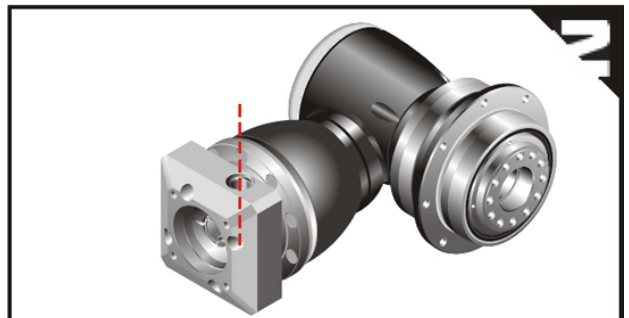

Motor und Getriebe Baugrosse kontrollieren und Planlagenflächen fettfrei reinigen



Abdeckschraube entfernen und Klemmschraube richtig justieren

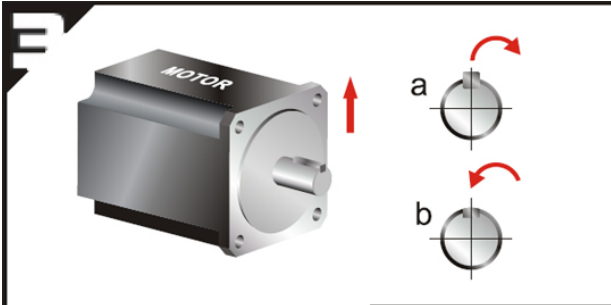

a Motorwelle Passfeder entfernen
b Falls notwendig Gleichgewicht Passfeder anbringen

Korrekte Montage
Beachten dass Passfeder Loch und eventuelle flache Seite der Antriebswelle senkrecht gegenüber Klemmschraube sitzt

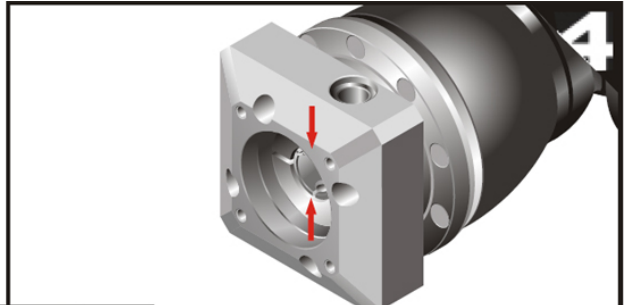

Motorwelledurchmesser kontrollieren und falls notwendig Distanzhülse anbringen

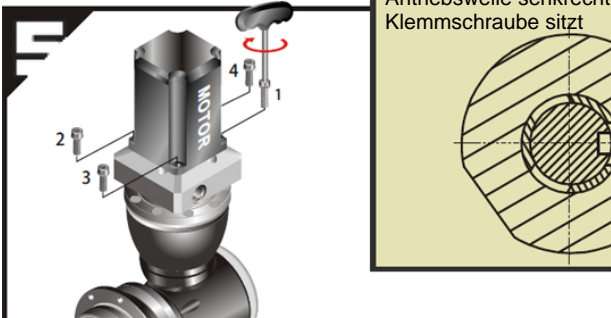

In Vertikale Position montieren. Motorbolzen (inkl. Sicherungsringen) in Reihenfolge 1 - 4 anziehen bis 5 % von vorgeschriebenen Drehmoment (siehe Tabelle 1).

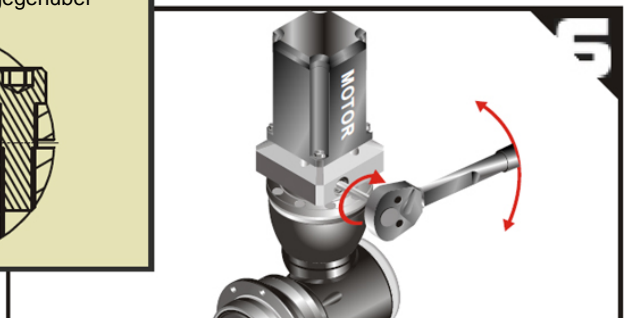

Ziehe Klemmnabebolze an mit Drehmomentschlüssel bis vorgeschriebene Drehmoment (siehe Tabelle 2)

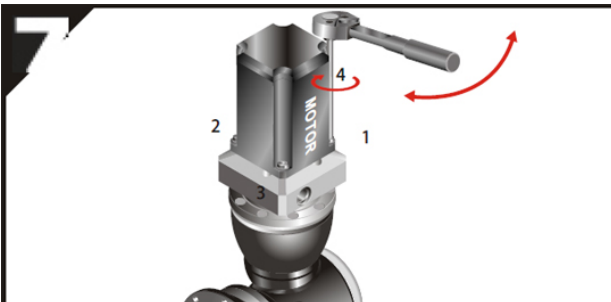

Ziehe Motorbolzen an in Reihenfolge 1 - 4 bis vorgeschriebene Drehmoment (siehe Tabelle 1)

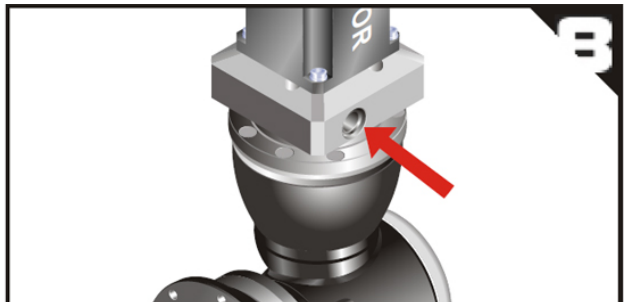

Abdeckschraube einschrauben und sichern

**MOTOR ANBAU ANLEITUNG****Tabelle 1** Empfohlen Anzugsdrehmoment für Motor Befestigungsschraube

Bolzen-Größe	Schlüsselweite	Festigkeitsklasse 8.8 Anzugsdrehmoment		Festigkeitsklasse 10.9 Anzugsdrehmoment		Festigkeitsklasse 12.9 Anzugsdrehmoment	
	[mm]	[Nm]	[In-lbs]	[Nm]	[In-lbs]	[Nm]	[In-lbs]
M3 x 0.5P	2.5	1.3	12	1.8	16	2.1	19
M4 x 0.7P	3	3	27	4.1	37	4.9	44
M5 x 0.8P	4	6.1	55	8.2	73	9.8	87
M6 x 1P	5	11	98	14	124	17	151
M8 x 1.25P	6	25	222	34	302	41	364
M10 x 1.5P	8	49	434	67	594	80	709
M12 x 1.75P	10	85	753	116	1028	139	1232
M14 x 2P	12	137	1214	186	1648	223	1976
M16 x 2P	14	210	1860	286	2534	343	3038

Tabelle 2 Empfohlen Anzugsdrehmoment für die KlemmnabeBolzen

Baugröße	Ø(C3)	8	11	14	19	24	28	32	35	38	42	48	55	
AH064	2-Stufig	M5	M5	M5	-	-	-	-	-	-	-	-	-	
AH090		-	M5	M6	M6	-	-	-	-	-	-	-	-	
AH110		-	-	M6	M8	M10	-	-	-	-	-	-	-	
AH140		-	-	-	M8	M10	M10	M10	M12	M12	-	-	-	
AH200		-	-	-	-	M10	M10	M10	M12	M12	M12	M16	-	
AH255		-	-	-	-	-	-	-	M10	M12	M12	M12	M16	-
AH285		-	-	-	-	-	-	-	-	M12	M12	M12	M16	-
AH355		-	-	-	-	-	-	-	-	-	M12	M12	M16	M16
AHKA285	3-Stufig	-	-	-	-	-	-	M10	M12	M12	M12	M16	-	
AHKA355		-	-	-	-	-	-	M10	M12	M12	M12	M16	-	
AHKA450		-	-	-	-	-	-	-	M12	M12	M12	M16	M16	
AHKB090	3-Stufig	M5	M5	M5	-	-	-	-	-	-	-	-	-	
AHKB110		-	M6	M6	M6	-	-	-	-	-	-	-	-	
AHKB140		-	-	M8	M8	M10	-	-	-	-	-	-	-	
AHKB200		-	-	-	M10	M10	M10	M10	M12	M12	-	-	-	
AHKB255		-	-	-	-	M10	M10	M10	M12	M12	M12	M16	-	
AHKB285		-	-	-	-	-	-	M10	M12	M12	M12	M16	-	
AHKB355		-	-	-	-	-	-	-	M12	M12	M12	M16	-	
AHK285	4-Stufig	-	-	-	-	M10	M10	M10	M12	M12	-	-	-	
AHK355		-	-	-	-	M10	M10	M10	M12	M12	-	-	-	
AHK450		-	-	-	-	-	-	M10	M12	M12	-	-	-	

Bolzen Größe	[mm]	M5 x 0.8P	M6 x 1P	M8 x 1.25P	M10 x 1.5P	M12 x 1.75P	M16 x 2P
Schlüsselweite	[mm]	4	5	6	8	10	14
Anzugsdrehmome	[Nm]	9,8	17	41	80	139	343
	[In-lbs]	87	151	364	709	1232	3038

Bemerkung: Die Anzugsmomente dürfen bis 20% höher sein als die oben angegebene Werten.

Apex Dynamics bvChurchillaan 101
NL-5705 BK Helmond
The Netherlands

Tel. : +31 (0)492 509 995

Fax : +31 (0)492 509 997

E-mail : sales@apexdyna.nl

Für weitere Informationen, besuchen Sie unsere Website: www.apexdyna.nl**High Precision Planetary Gearboxes**